

DIEDRICH™

— **ROASTERS** —



IR-12 AUTO ROASTER GUIDE

Diedrich Roasters LLC, 850 Hawthorne Ave., Ponderay, ID 83852
Phone: (844) 343-3742 Email: Info@DiedrichRoasters.com

Original Instructions
GUI-IR12A-0001, Rev 003

TABLE OF CONTENTS

1. IR-12 Auto Roaster Technical data	2
2. IR-12 Auto Roaster Drawings.....	2
Front View	3
Left Side View	4
Rear View.....	5
Right Side View.....	6
Top View	7
Front Left – Isometric View	8
Front Right – Isometric View.....	9
Top View with Space and Utility Connection Information	10
Isometric View – Full Roasting System	11
3. Facility and Installation preparations	12
4. Exhaust ducting	12
5. Data Logging	14
6. Additional documents and information	14
7. CERTIFICATES & CONFORMITIES	14
Standard for Gas Food Service Equipment, ANSI Z83.11b-2016/CSA 1.8b-2016 Certificate Of Compliance	15
UL 508A, Industrial Control Panels C22.2 No. 14, Industrial Control Equipment Certificate Of Compliance.....	16
EU Declaration of Conformity	17

1. IR-12 AUTO ROASTER TECHNICAL DATA

General Information		
Green coffee capacity, Min-Max	13.25 - 26.5 lb	6 –12 kg
Dimensions, maximum L x W ¹ x H	55 ¾ x 48 ⅛ ¹ x 76 ⅝ in	1416 x 1222 ¹ x 1946 mm
Shipping weight (Approximate)	1,320 lb	599 kg
Shipping crate size, LxWxH	60 x 39 x 77 in	1524 x 991 x 1956 mm
Full batch roast time to 440°F (227°C)	13 – 16 Minutes	
Hourly output ² , 15 minute roast	106 lb/hr	48 kg/hr
Exhaust airflow, Max	363 scfm	617 scmh
Exhaust duct outside diameter	8 in	203 mm
Temperature high limit	475°F burner off, 485°F pilot off	246°C burner off, 252°C pilot off
Gas Information		
Gas Types (others if pre-approved)	Liquid Propane (LP) or Natural Gas (NG)	
Maximum consumption	90,000 BTU/hr	26 kW
Typical consumption per roast ³	18,670 BTU	5.47 kWh
Inlet Pressure LP	12-14 in WC	30-35 mbar
Inlet Pressure NG	8-9 in WC	20-22.5 mbar
Inlet gas supply connection	½ in male NPT on roaster	

Electrical Information	
Volts AC (1-Phase)	100-120V or 200-240V
Frequencies	50Hz or 60Hz
Full Load Amps	13.3 Amps at 120V 60Hz 7.5 Amps at 230V 50Hz
Roaster Main Breaker size	15 Amps at 120V 60Hz 10 Amps at 230V 50Hz

2. IR-12 AUTO ROASTER DRAWINGS

This section contains drawing views with dimensions and component descriptions. These drawing are valuable for familiarization with the Diedrich IR-12 Auto roaster and for space and utility connection planning. There are also drawings of the IR-12 Auto roaster with optional loader, destoner, cyclone, and afterburner. This information is subject to change.

¹ Maximum width is with the HMI arm fully extended. See the top view drawing for the width max/min range.

² Hourly “green” coffee output. Thus, the weight has not been corrected for moisture loss.

³ Based on a 13-16 minute roast to 440°F/227°C.

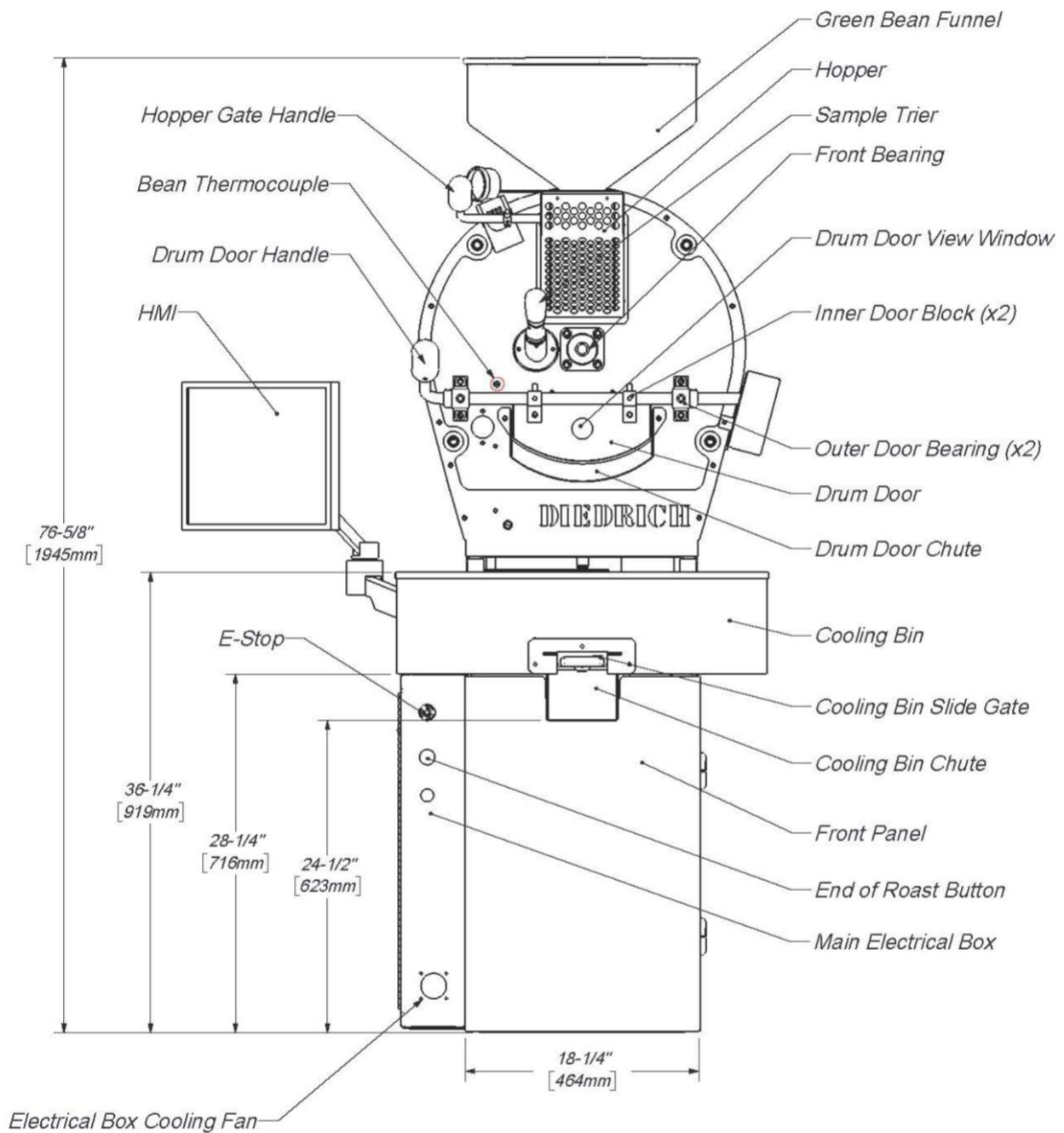

Front View

Scale 1:12

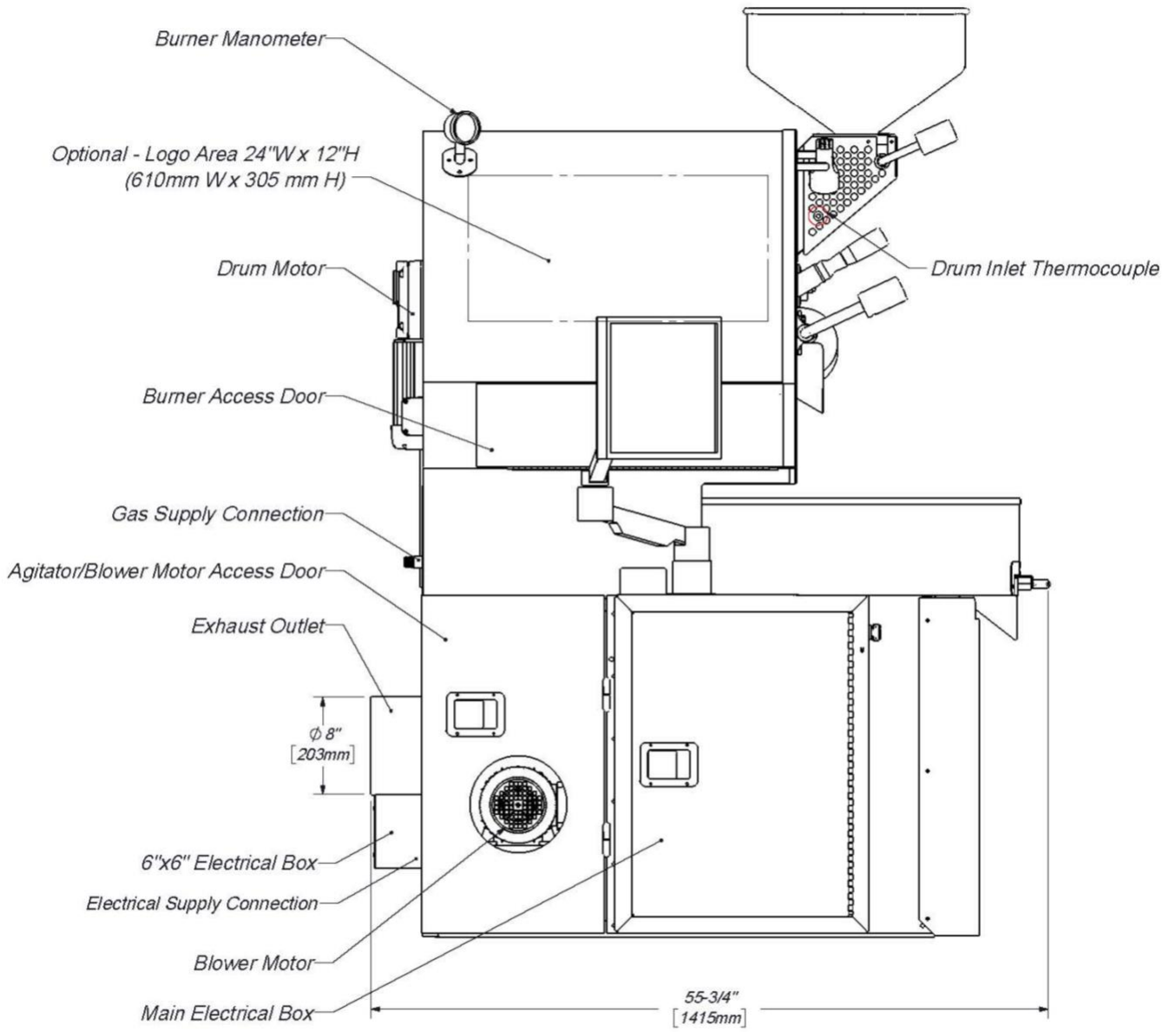

Left Side View

Scale 1:12

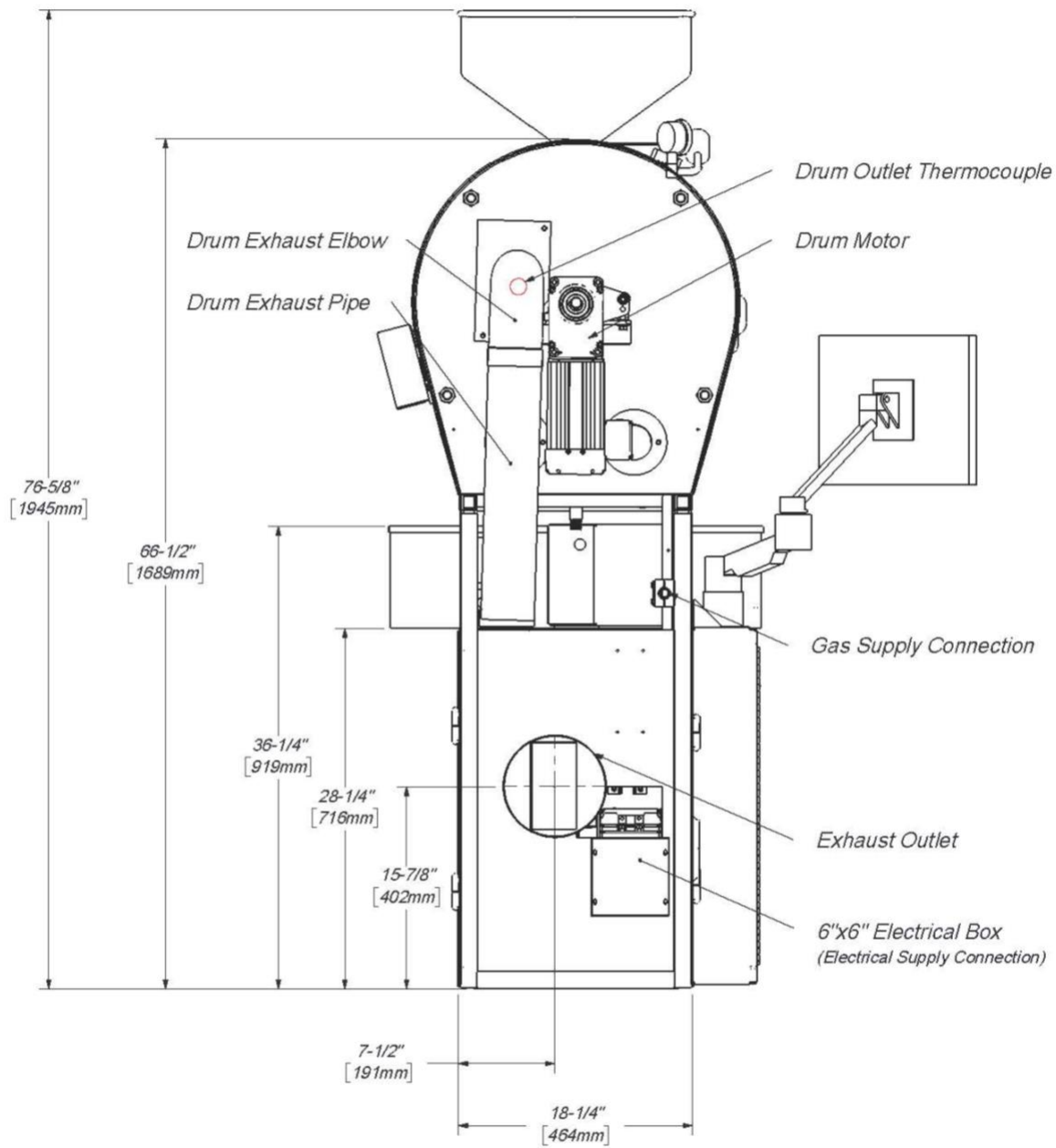

Rear View

Scale 1:12

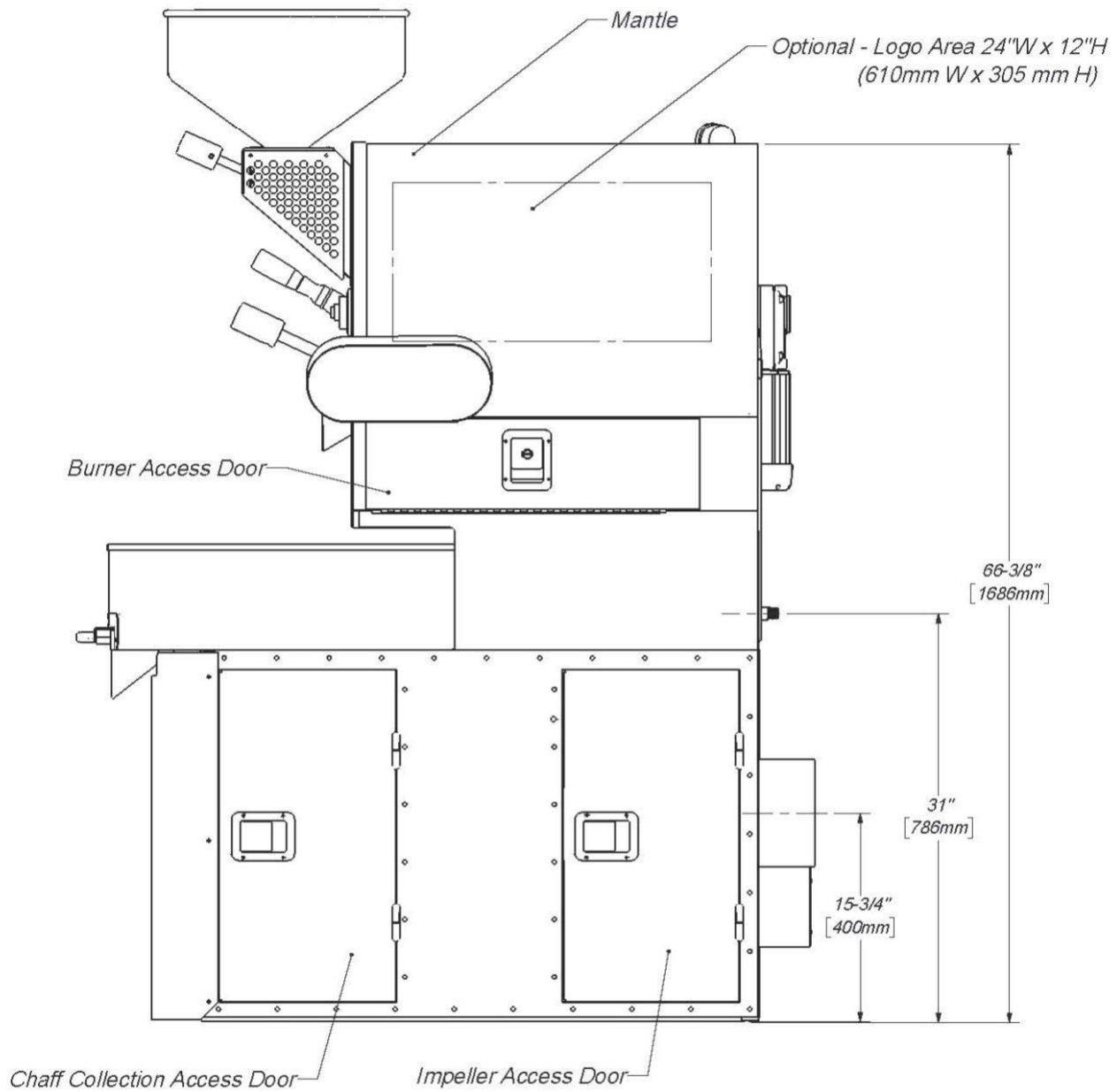

Right Side View

Scale 1:12

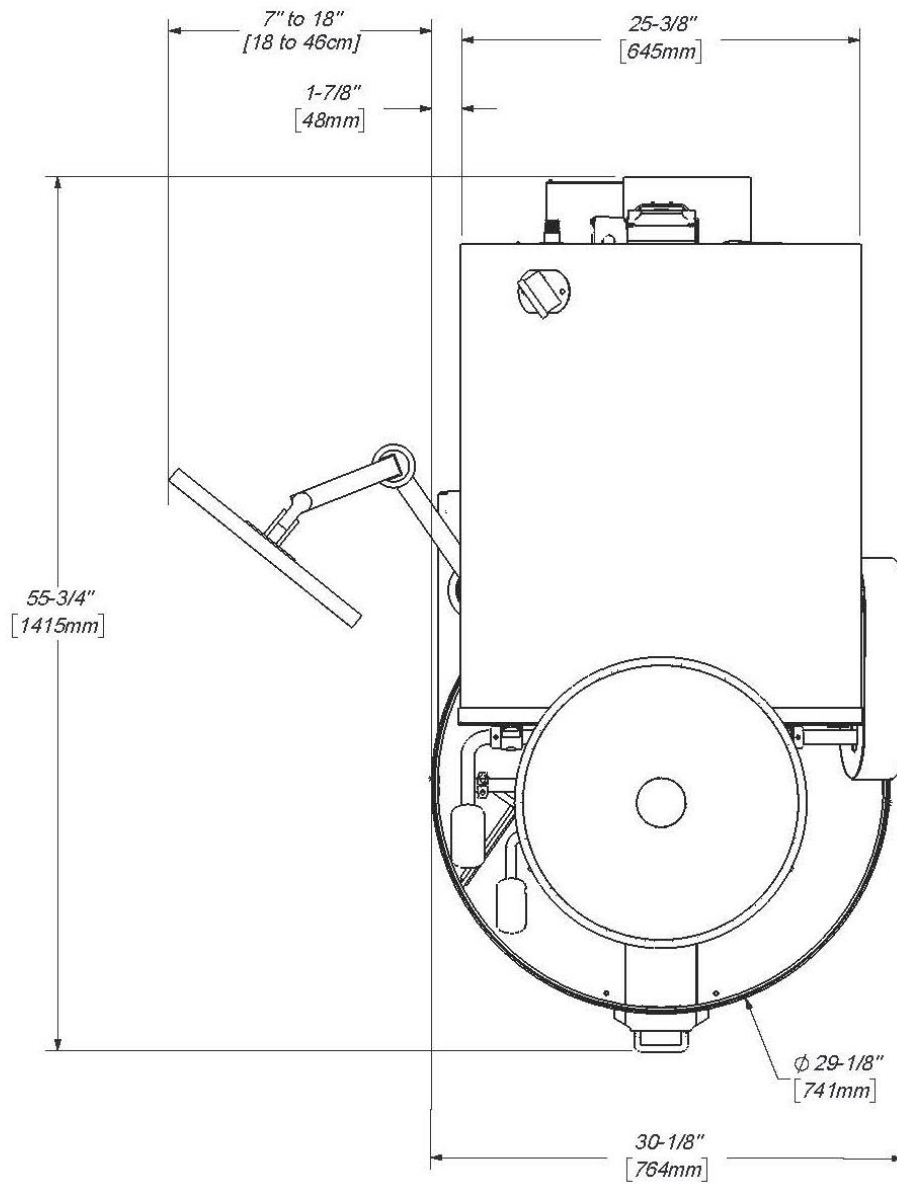

TOP VIEW

Scale 1:12

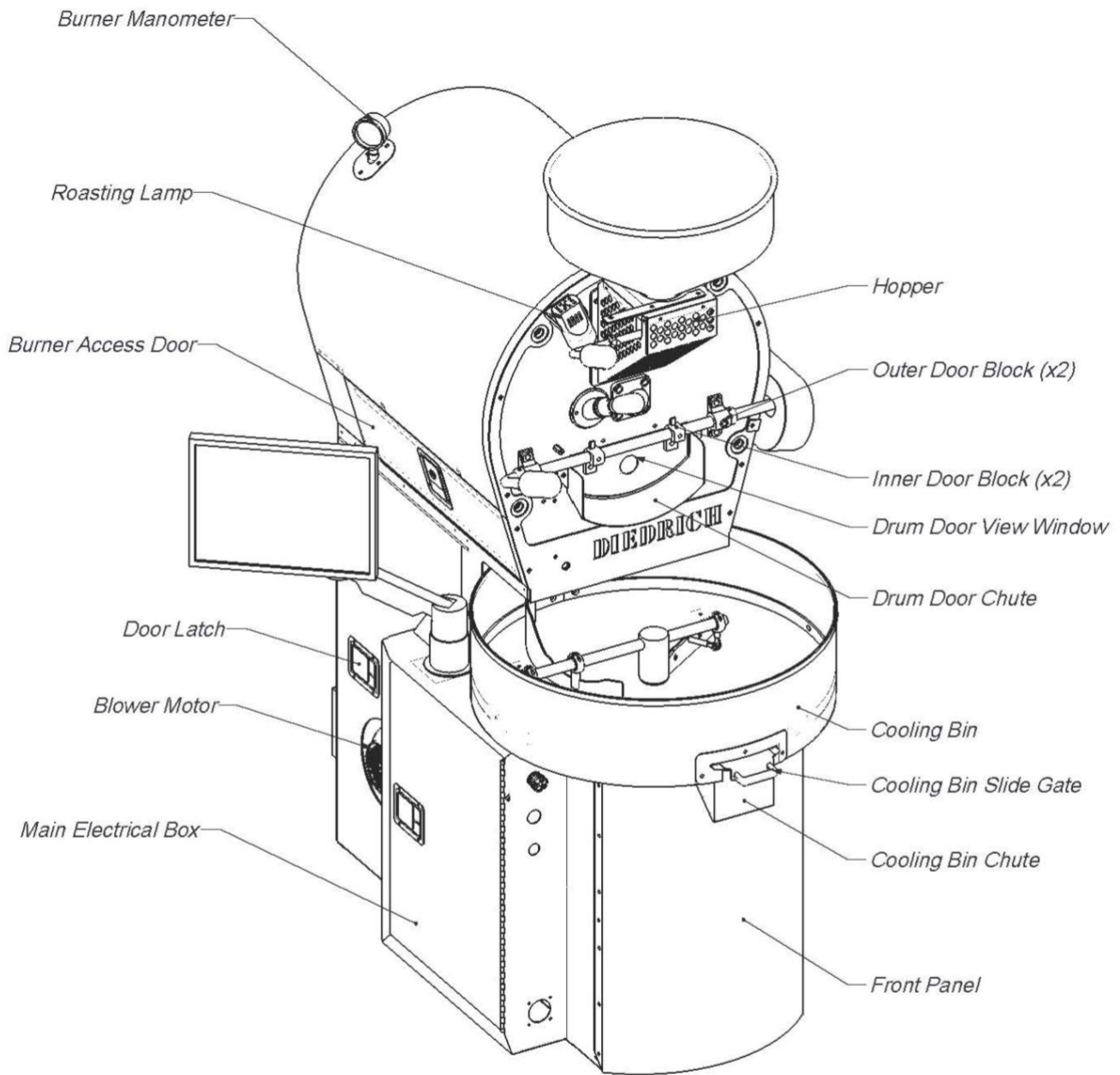

Front Left - Isometric View

Scale 1:12

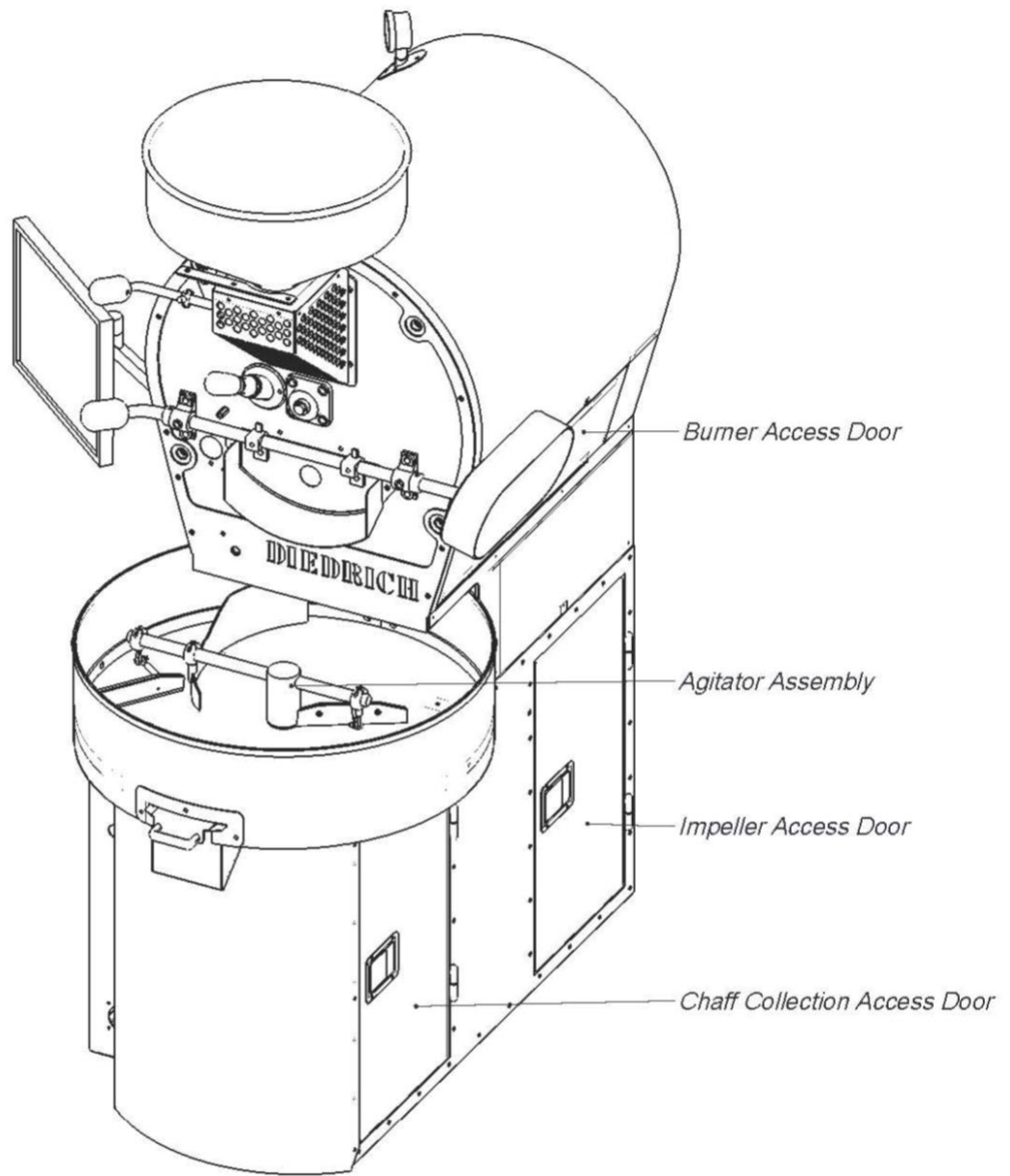

Front Right - Isometric View

Scale 1:12

Space and Utility Connection Information

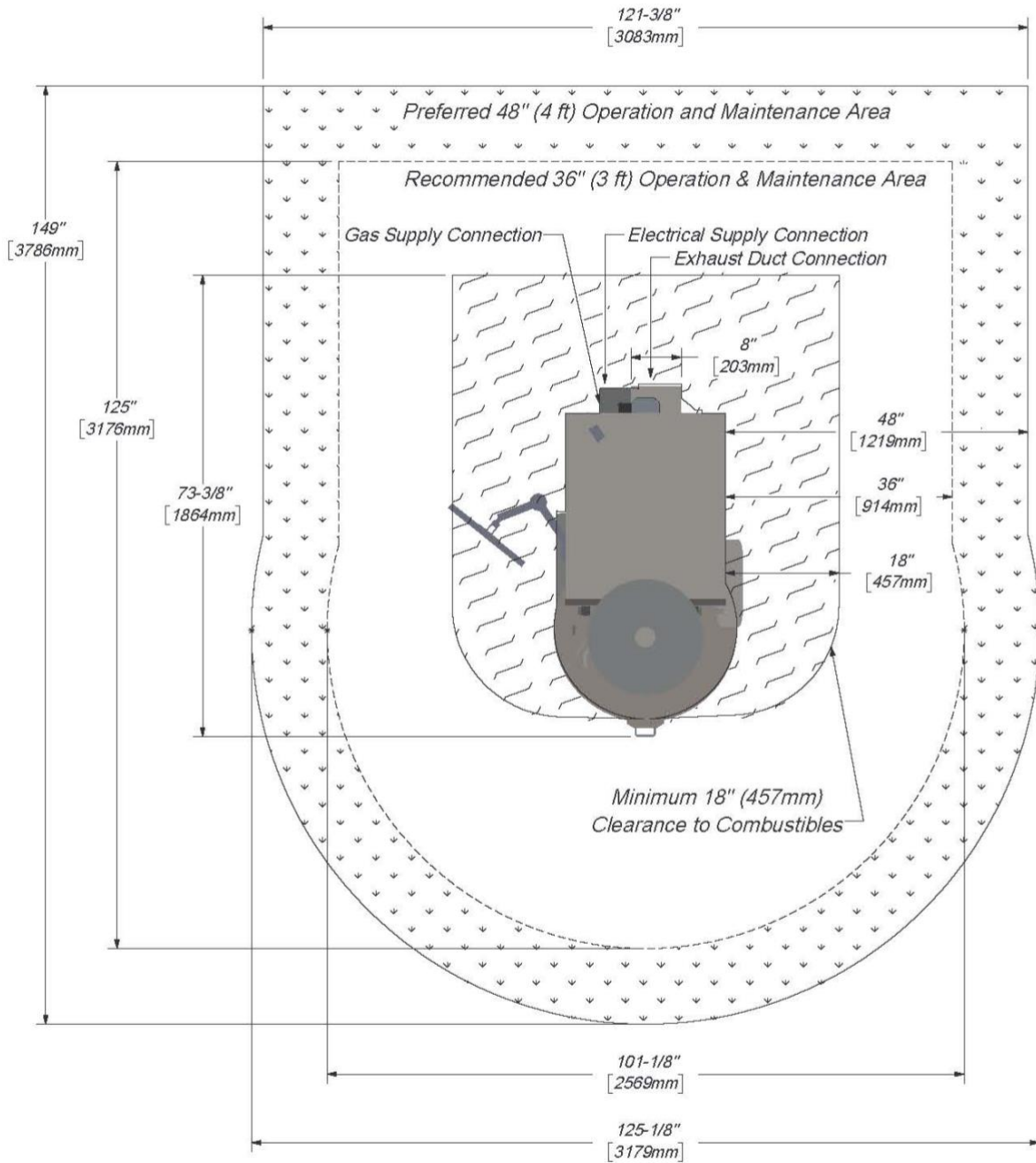

Top View

Scale 1:24

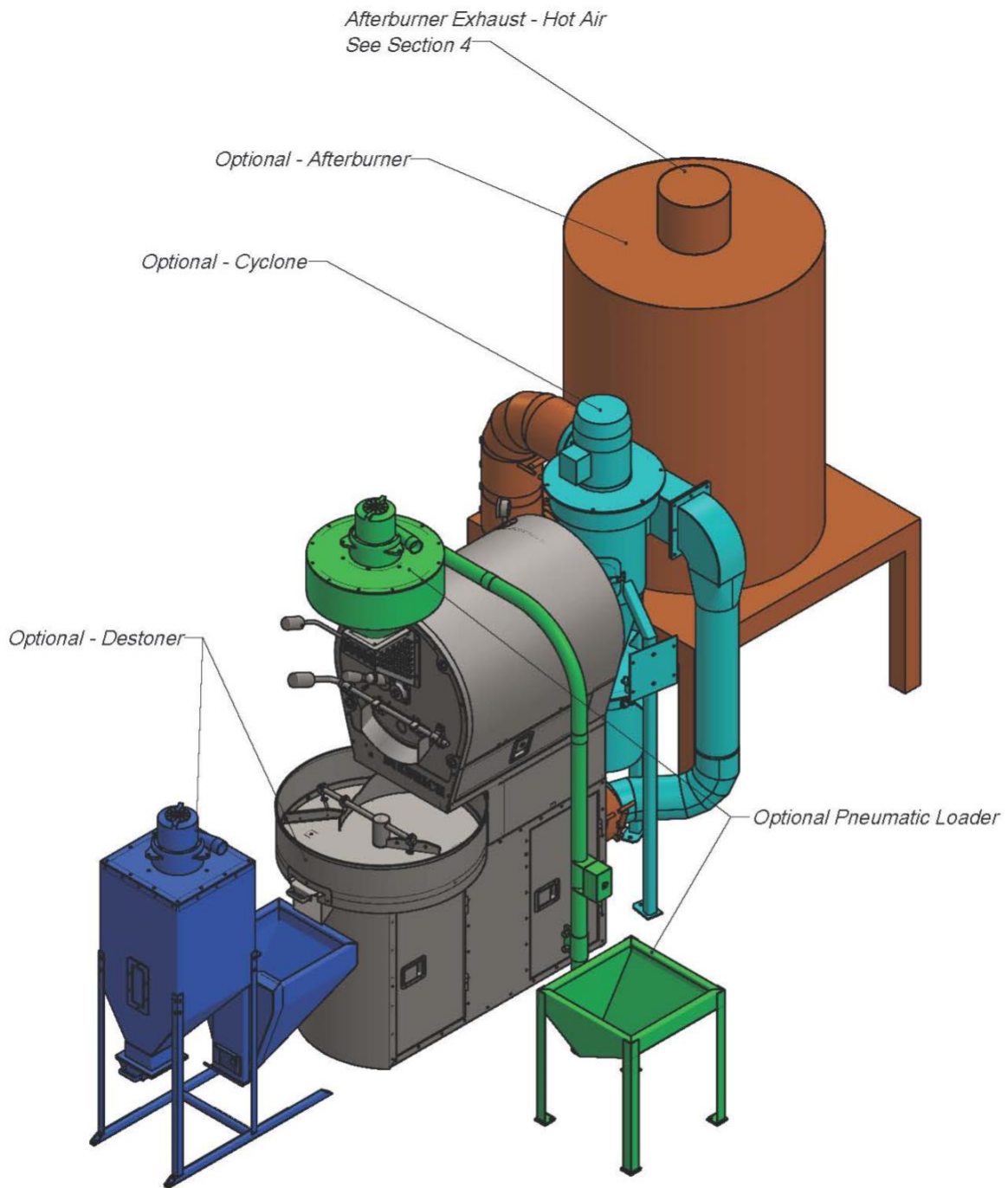

Scale 1:20

Isometric View - Full Roasting System

For More Information Request Layout For Purchased Options

3. FACILITY AND INSTALLATION PREPARATIONS

It is suggested that the roaster be operated under the following environmental conditions:

- a) Temperature range: 41°F and 86°F; +5°C and +30°C;
- b) Relative humidity up to 50% at a maximum temperature of 86°F/30 °C;
- c) Altitudes up to 3281 ft/1000 m above mean sea level;
- d) Transportation and storage temperature range: - 77°F/25°C to 131°F/55°C.

Review the Installation and Operation Manual upon purchase. Read it thoroughly prior to installation of the roaster and/or ancillary equipment.

Check local building/fire codes and regulations. Local regulations and requirements will govern in the event they exceed or contradict information provided by Diedrich Roasters LLC, in this document or elsewhere.

It is the purchaser's responsibility to ensure the appropriate codes and regulations, specific to their area, are followed and met.

Obtain any required permits such as building and air quality permits. Requests for information or assistance with permitting and/or certification forms must be submitted to Diedrich within 30 days of purchase. Anticipate approximately 15 business days from submittal of forms for Diedrich to complete our part.

Determine the layout/location of the roaster and any ancillary equipment.

Clearance to combustibles must be a minimum of 18 inches (457 mm) from the sides and the back of the roaster, as well as from the exhaust pipe stub. However, 3-4 feet (1-1.2 meters) minimum clearance is recommended for operation, maintenance, and repairs. See the Top View Space and Utility Connection Information drawing.

Diedrich Roasters personnel may assist with a customized layout to fit within a specified space. This service is primarily available for Diedrich systems with roasters and other ancillary equipment.

Seek licensed and certified professionals for preparation, installation, and connection of electrical, gas, and exhaust ducting to the roaster and any ancillary equipment.

Make sure the appropriate electrical power is available. Ancillary equipment such as the loader, destoner, and afterburner will require their own power source, since they are not powered by the roaster. See Section 1 of this document and the Installation and Operation Manual for additional information.

Make sure the appropriate gas supply is available. See Section 1 of this document and the Installation and Operation Manual for additional information.

The roasting system will remove fresh air from the building. An additional fresh air inlet may be required to allow "make up air". See Section 1 of this document for roaster airflow information. Consultation with a licensed Heating, Ventilation, and Air Conditioning (HVAC) contractor is recommended.

Ensure the appropriate size and type of exhaust ducting is installed. Section 1 of this document, and the "Exhaust Ducting" section below, provide technical data and other pertinent information. *The exhaust ducting can be expensive and have a long lead time.*

4. EXHAUST DUCTING

One of the most important aspects of the roaster installation is the use of an approved exhaust ducting system. Its design will greatly affect the performance of the roaster and the product quality. The cost and time to order and install the exhaust ducting are important factors for the customer to consider.

Designing the exhaust system requires a trained professional to calculate the efficiency of the system and the proper size of ducting. The ducting must be of sufficient diameter to accommodate the air flow (SCFM - standard cubic feet per minute

or SCMH - standard cubic meters per hour) and meet the static pressure requirement (noted below). A licensed engineer or Heating, Ventilation, Air Conditioning (HVAC) professional can assist you with the best ducting layout for your site. Pertinent information the contractor will need, such as the diameter of the exhaust ducting on the roaster and the maximum exhaust air flow in SCFM, is located in the Section 1 *Technical Data* table.

All makes of roasters and afterburners have a blower which forces exhaust air into the ducting. The oils and residues in the roaster exhaust air are flammable. In the event of a ducting/flue fire, the internal duct temperatures can exceed 1000° F (538°C), which could cause nearby combustible materials to ignite. For this reason, Diedrich recommends, at a minimum, stainless steel, double wall, positive pressure grease ducting that meets the applicable region/local standards, such as UL for the USA, ULC for Canada, and CE for the European Union.

For Roasters (with or without cyclones).

Ducting must be suitable for 500°F (260°C) continuous, 2,000°F (1,093°C) for 30 minutes, and comply with UL-1978/ULC-SC662 Standard for Grease Ducts in the USA/Canada, and/or equivalent standards for other countries (such as CE standards for the European Union).

Installation must be done in accordance with appropriate NFPA standards in the USA or equivalent standards in other countries. The installation must also comply with the manufacturer's installation specifications and allowable distance to combustible/noncombustible materials.

For Roasters with an Afterburner.

Ducting from the afterburner must be suitable for 1,000°F (538°C) continuous, 1,400°F (927°C) intermittent, and comply with UL-103/ULC_ORD-C959 in the USA/Canada, and/or equivalent standards for other countries (such as CE standards for the European Union).

Installation must be done in accordance with appropriate NFPA standards in the USA or equivalent standards in other countries. The installation must also comply with the manufacturer's installation specifications and allowable distance to combustible/noncombustible materials.

There are companies that offer ducting products that meet both of the standards noted above (UL 1978 and UL 103). Some of these companies are listed below along with their websites and contact information.

Van-Packer www.vpstack.com; 888-877-8225, and/or VPTech@vpstack.com
Selkirk www.selkirkcorp.com and/or customer service at 800-848-2149
Jeremias www.jeremiasinc.com and/or e-mail JeremiasTech@JeremiasInc.com
DuraVent www.duravent.com and/or e-mail customerservice@duravent.com

Another consideration when designing an exhaust ducting system is the static pressure. The static pressure is the backpressure or suction within the system. The exhaust system must be designed to operate with a static flue pressure between negative 0.15" WC (negative pressure – suction) and positive 0.25" WC (back pressure) at the exhaust of the roaster (cyclone or afterburner, as applicable) while in operation.

When venting your roaster, a direct vertical run is typically the most efficient and cost effective. Long horizontal runs and elbows will put a restriction on the airflow which may cause excessive backpressure. A booster fan may be needed to assist air movement if the system is too restrictive. A qualified ducting contractor/engineer should determine the best design for your specific installation.

A properly designed and installed chimney and rain cap is essential to the equipment performance and longevity. Water leaking in may cause an electrical short or damage the equipment. Your contractor will be able to coordinate with local jurisdictions for the correct cap. The cap should not have a screen since it will clog with residue of chaff over time.

The roaster (cyclone or afterburner, as applicable) MUST NOT support the weight of the exhaust system. Ducting must be connected to the roaster based on the ducting manufacturer's recommendation.



DANGER

DO NOT USE CLASS B OR SPIRAL-WRAP DUCTING UNDER ANY CIRCUMSTANCES.



DANGER

Fires are caused by failure to maintain a clean roaster and its exhaust ducting system. Regular cleaning of the roaster and exhaust ducting will prevent the buildup of residues that could cause fire.

5. DATA LOGGING

Listed below are the positions on the roaster from which data is collected during a roast cycle. Third party control of the air and fuel is not supported.

Bean Thermocouple

Displayed in Diedrich software

Logged and stored to profile data in Diedrich software

Logged through 3rd party software supporting Phidgets

Drum Inlet Thermocouple

Logged through 3rd party software supporting Phidgets

Drum Outlet Thermocouple

Logged through 3rd party software supporting Phidgets

Fuel Percentage (0-100%)

Displayed and controlled in Diedrich software

Logged and stored to profile data in Diedrich software

Air Position (0, 50, 100%)

Displayed and controlled in Diedrich software

Logged and stored to profile data in Diedrich software

6. ADDITIONAL DOCUMENTS AND INFORMATION

The information in this document is intended to assist customers with purchasing and facility preparation decisions. Upon purchase of a Diedrich Roaster, additional documentation will be provided. It is important for customers to read these documents in order to ensure that the installation and operation phases are smooth and safe. Please feel welcome to reach out to us with questions or information requests.

Phone: 844-343-3742

E-mail: Support@DiedrichRoasters.com

Website: DiedrichRoasters.com

Facebook: [Facebook.com/DiedrichRoasters](https://www.facebook.com/DiedrichRoasters)

Instagram: [Instagram.com/DiedrichRoasters](https://www.instagram.com/DiedrichRoasters)

7. CERTIFICATES & CONFORMITIES

Diedrich Roasters, LLC manufactures coffee roasters in compliance with UL or CE regulation. The roasters are built to order, specifically to the standards of the governing regulatory body in the country of operation. Please refer to your equipment data labels for reference to the regulatory specification to which the roaster has been built.

CERTIFICATE OF COMPLIANCE

Certificate Number 20170703-MH61804
Report Reference MH61804-20160628
Issue Date 2017-JULY-03

Issued to: Diedrich Roasters, LLC
24 Emerald Industrial Park Rd
Ponderay ID 83864

This is to certify that representative samples of GAS-FIRED FOOD SERVICE EQUIPMENT
Commercial Gas Fired Coffee Bean Roasters, models
IR-1, IR-2.5, IR-5, IR-12, CR-025, CR-035, CR-050,
CR-070

Have been investigated by UL in accordance with the
Standard(s) indicated on this Certificate.

Standard(s) for Safety: Standard for Gas Food Service Equipment, ANSI Z83.11b-
2016/CSA 1.8b-2016

Additional Information: See the UL Online Certifications Directory at
www.ul.com/database for additional information

Only those products bearing the UL Certification Mark should be considered as being covered by UL's
Certification and Follow-Up Service.

Look for the UL Certification Mark on the product.

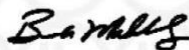

Bruce Mahrenholz, Director North American Certification Program
UL LLC

Any information and documentation involving UL Mark services are provided on behalf of UL LLC (UL) or any authorized licensee of UL. For questions, please
contact a local UL Customer Service Representative at <http://ul.com/aboutul/locations>



CERTIFICATE OF COMPLIANCE

Certificate Number 20160525-E478523
Report Reference E478523-20150831
Issue Date 2015-MAY-25

Issued to: DIEDRICH ROASTERS, LLC.
24 Emerald Industrial Park Road
Ponderay, ID 83864 USA

This is to certify that representative samples of Industrial Control Panels
USL, CNL - Industrial Control Panels – General Coverage.

Have been investigated by UL in accordance with the Standard(s) indicated on this Certificate.

Standard(s) for Safety: UL 508A, Industrial Control Panels
C22.2 No. 14, Industrial Control Equipment

Additional Information: See the UL Online Certifications Directory at
www.ul.com/database for additional information

Only those products bearing the UL Certification Mark should be considered as being covered by UL's Certification and Follow-Up Service.

Look for the UL Certification Mark on the product.

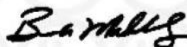

Bruce Mahrenholz, Director North American Certification Program
UL LLC

Any information and documentation involving UL Mark services are provided on behalf of UL LLC (UL) or any authorized licensee of UL. For questions, please contact a local UL Customer Service Representative at <http://ul.com/aboutul/locations>.



EU DECLARATION OF CONFORMITY

MANUFACTURER: Diedrich Roasters, LLC
850 Hawthorne Avenue
Ponderay, Idaho 83852 USA
Phone: 844.343.3742
URL: www.diedrichroasters.com

EU CONTACT ADDRESS: Jamie Banwell
Rubiaceae Consulting Ltd
Unit 3a Imperial Studios
Imperial Road
Fulham
SW6 2AG

MODEL / TYPE: IR Series: IR-1, IR-2.5, IR-5, IR-12

DESCRIPTION: Coffee Roaster

REPORTS: F2P23881D-01S, F2P23881D-01E

DIRECTIVES: Machinery Directive 2006/42/EC, EMC Directive 2014/30/EU

STANDARDS CONSIDERED, FULL OR IN PART:

- EN / ISO 13849-1:2015
- EN 60204-1:2018
- EN 61000-6-3:2007+A1:2011
- EN 61000-6-1:2007

THIRD PARTY TESTING:



www.f2labs.com

26501 Ridge Road
Damascus, MD 20872 USA
Phone: 301.253.4500
Fax: 301.253.5179
Toll Free: 877.405.1580

16740 Peters Road
Middlefield, OH 44062 USA
Phone: 440.632.5541
Fax: 440.632.5542

8583 Zionsville Road
Indianapolis, IN 46268 USA
Phone: 317.610.0611
Fax: 317.610.0525

Diedrich Roasters, LLC declares under its sole responsibility that the **IR series Coffee Roaster**, is in conformity with the Machinery Directive 2006/42/EC and the EMC Directive 2014/30/EU.

Authorized by:

A handwritten signature in blue ink that reads 'Karl Schmidt'.

(signature)

Date: September 16, 2021

Name: Karl Schmidt

Title: CEO

Location: Ponderay, ID